

CAD FILE:

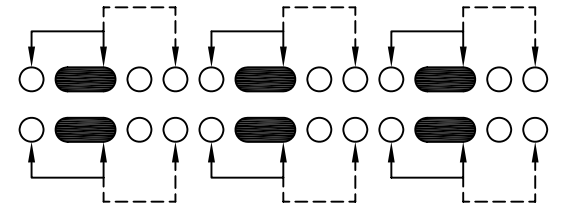

SCHEMATIC (NON SPECIFIED)

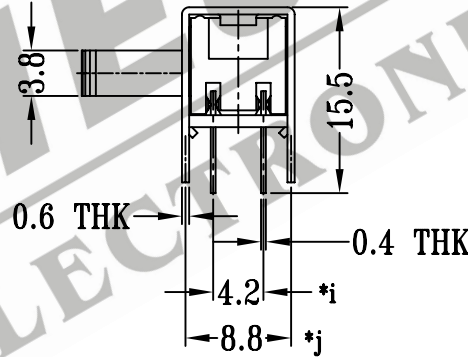
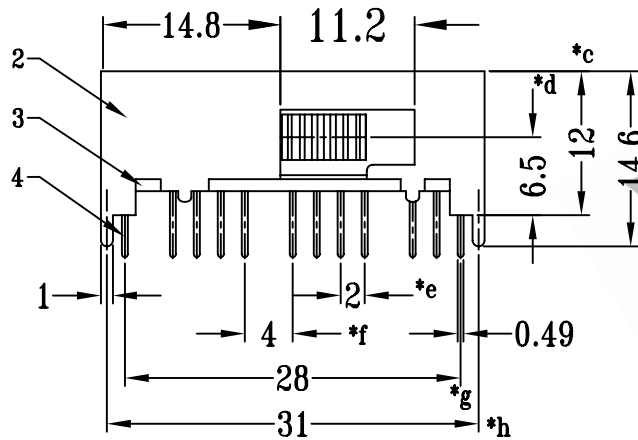
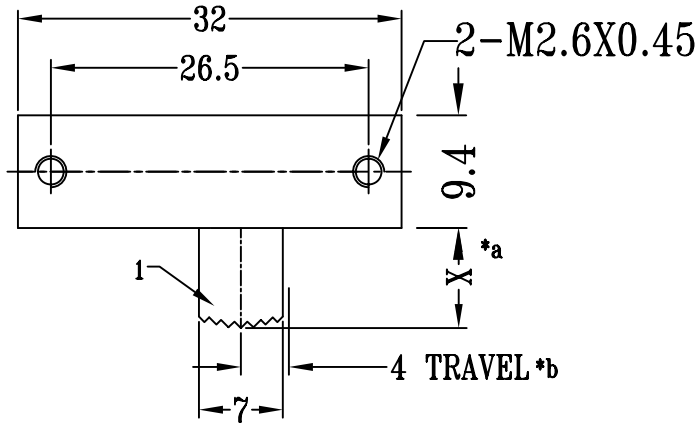
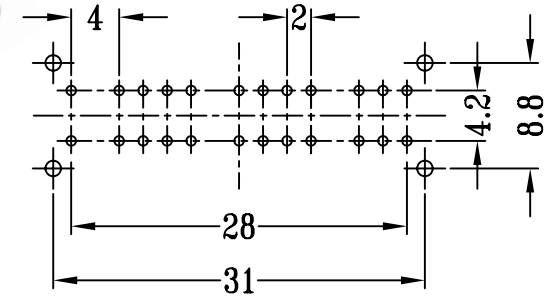

P.C.B LAYOUT

注:带*表示关键尺寸(10个)

8					TOLERANCE UNLESS SPECIFIED	SHENZHEN XIEJIA ELECTRONICS CO.,LTD.					
7	STEEL BALL	STEEL	1	NATURAL		WITHIN: 1.5±0.1mm OVER: 1.5±0.2mm	ISSUE	DATE	DESCRIPTIONS OF REVISION		APPD.
6	SPRING	STEEL WIRE	1	TEMPER	TITLE : HORIZONTAL SLIDE SWITCH MODEL: SK-62H12 ALL MATERIALS MUST BE COMPLIANT TO ROHS		UNIT : mm		DRWG NO.: XJ-DR-SK62H12-00		
5	CONTACT CLIP	PBS STRIP	6	Ag PLATED		SCALE: 3:2	CHK'D	ZHOUYU	2005-9-8		
4	TERMINAL	BRASS STRIP	18	Ag PLATED OVER Ni PLATED			APPD.	FANGYING	2005-9-8		
3	BASE	PHENOLIC RESIN	1	NATURAL		APPD.	KANGXINAN	2005-9-8			
2	FRAME	STEEL STRIP	1	Ni PLATED							
1	KNOB	POM	1	BLACK							
NO.	PARTS	MATERIALS	Q'TY	FINISH							